

RDO65 series IP65 LED recessed downlight with high efficacy LED chips.
Powder coated die-cast housing and trim with opal PMMA diffuser.
RDO65 IP65 series recessed downlight designed for indoor and outdoor applications.

<u>CRI:</u>	CRI80+
<u>Lamp's Life Time:</u>	50,000Hrs L70 / B10
<u>Beam Angle:</u>	90°
<u>Driver options:</u>	Non-dimmable, Triac dimmable, DALI/DSI dimmable
<u>IP Rating:</u>	IP65
<u>Colour Temperature:</u>	3000K / 4000K / 5000K
<u>Trim Colour:</u>	White finish

Applications:

Hospitals, Schools, Hotels, Shops, Supermarkets, Foyers, Bathrooms, Changing rooms and Canopies

Lumen output based on Absolute lumens, 4000K LED chip and manufacturers rated mA drivers.

*** NOTE: Dimensions and Cut Out sizes may change without notification.

Rytec Lighting Australia Pty Ltd

Cat	Watt	Colour Temperature	Lumen Output	CRI	Beam	Size Dia x Height	Cut Out	IP
RDO65-13	13W	3000K 4000K	1197 1317	80+	90°	115 x 56	Ø 95	IP65
RDO65-18	18W	3000K 4000K	1637 1808	80+	90°	155 x 67	Ø 120	IP65
RDO65-25	25W	3000K 4000K	2286 2624	80+	90°	195 x 47	Ø 175	IP65
RDO65-35	35W	3000K 4000K	3238 3556	80+	90°	235 x 55	Ø 205	IP65

Optional Extras

Options	Suffix	Comments
Triac dimmable	DM	Triac dimmable LED driver
DALI/DSI dimmable	EBD	DALI or DSI dimmable LED driver

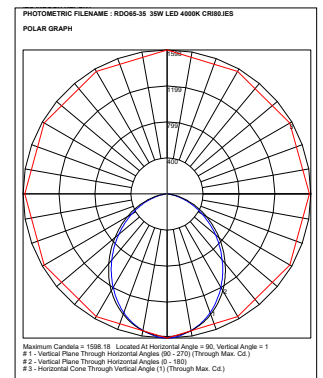
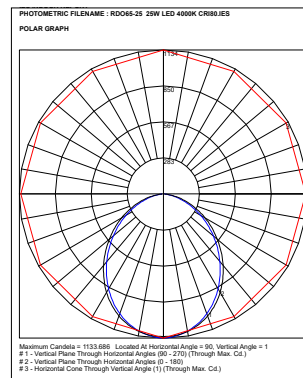
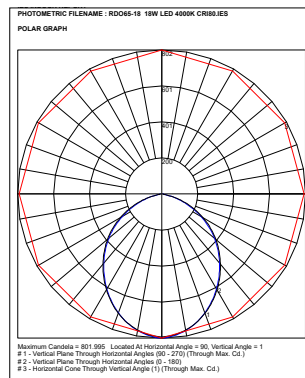
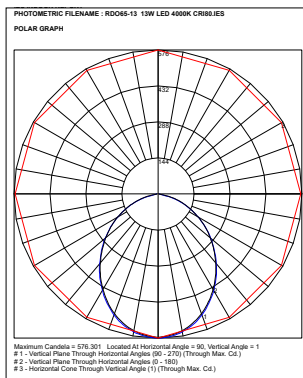

Lumen output based on Absolute lumens, 4000K LED chip and manufacturers rated mA drivers.

*** NOTE: Dimensions and Cut Out sizes may change without notification.