



BFLED series LED Flood light series. Slime housing, high performance output. Designed for general area illumination.

- Powder coated aluminium housing
- Clear tempered glass lens
- CREE High performance LED chips
- Philips integral electronic LED driver

<u>Colour Temperature:</u>	3000K / 4000K / 5000K
<u>LEDs Life Time:</u>	50,000Hrs L70 / B10
<u>CRI:</u>	CRI70+
<u>Beam Angle:</u>	60° / 120°
<u>Driver options:</u>	Non-dimmable
<u>IP Rating:</u>	IP65
<u>IK Rating:</u>	IK08
<u>Mounting:</u>	Surface mounted with adjustable mounting bracket
<u>Available Colour:</u>	Black finish

Applications:

Industrial, Commercial, General are illumination, Car park, Car park entrance

Lumen output based on Absolute lumens, 4000K LED chip and manufacturers rated mA drivers.

*** NOTE: Dimensions and Cut Out sizes may change without notification.

Rytec Lighting Australia Pty Ltd

Cat	Watt	Colour Temperature	Lumen Output 90°	Beam	Size L x W x D	IP
BFLED50	50W	4000K	7139	120°	310x250x48	IP65
BFLED100	100W	4000K	14277	120°	402x325x54	IP65
BFLED150	150W	4000K	20643	120°	430x360x54	IP65
BFLED200	200W	4000K	27289	120°	470x390x54	IP65

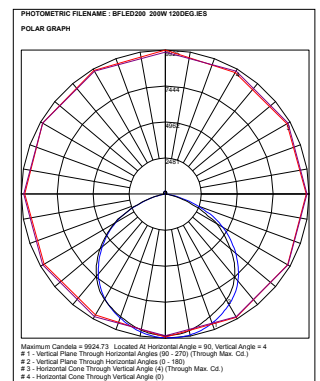
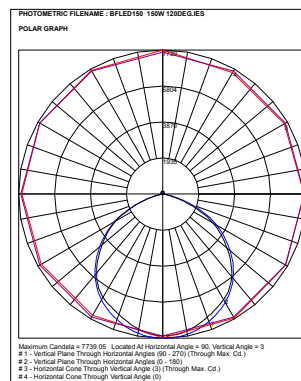
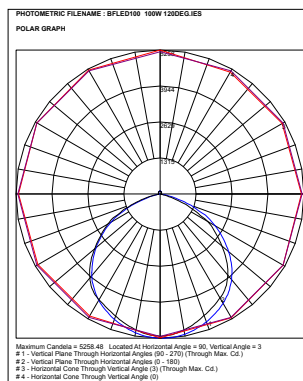
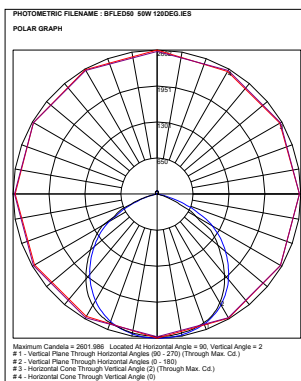
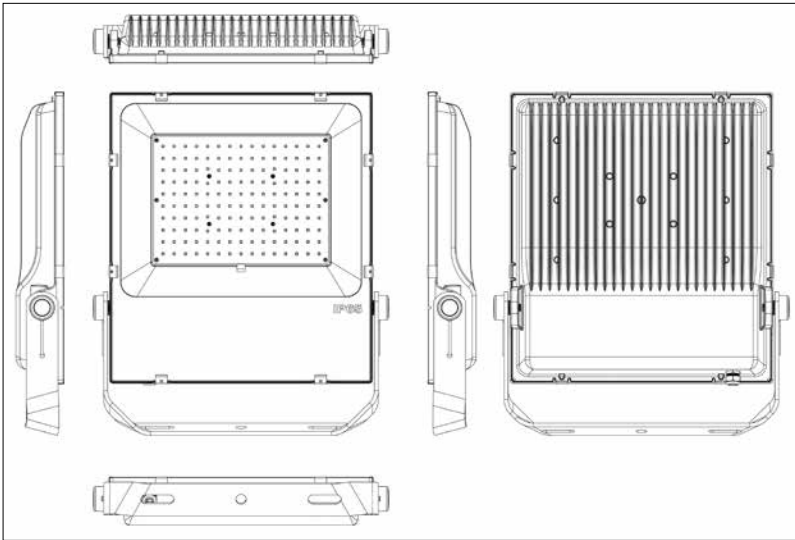

Lumen output based on Absolute lumens, 4000K LED chip and manufacturers rated mA drivers.

*** NOTE: Dimensions and Cut Out sizes may change without notification.